

FIELD INSTALLATION RETRO FIT KIT: *Installing DevD Control Board Kit*

The document outlines steps to install the HRP Electrical Kit into HRP-A (9-pin) cabinet. For Omega HRP units built 2009-2018.

Note: This kit is designed to work with several motor variants: PSC (factory default); EON-42 and X-13 Discrete ECM.

Included in Kit:

- New Control Board Kit (Control board and components)
- Updated Disconnect Cover Plate
- 3-Speed Fan Switch

Before starting:

Disconnect power to the unit and turn off at breaker.

Omega is not responsible for any damage to equipment or property as a result of improper installation. All electrical connections should be done by only certified electrical technicians and/or verified by local electrical authority.

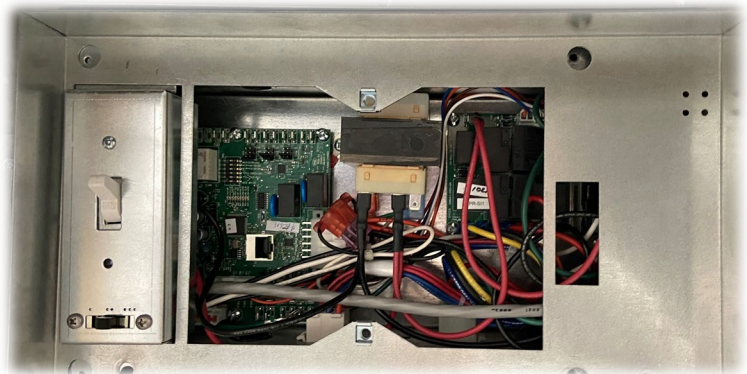
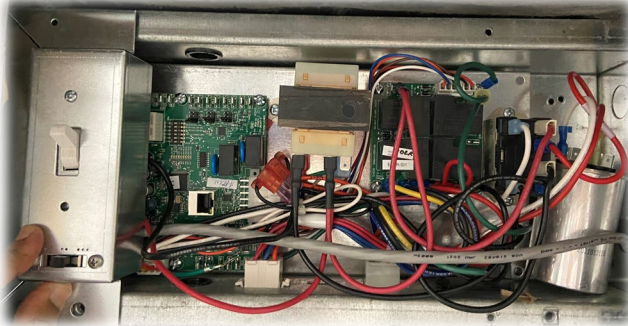

STEP 2) Preparation of Electrical Box.

- 1) Disconnect can remain wired to LINE SIDE (not shown here). Power and thermostat leads should be left inside electrical box (not shown here).
- 2) Below picture shows all existing components, disconnect cover and as well as panel mount connectors removed.



STEP 3) Installing Board.

- 1) Insert all 3 panel mount moxex connectors provided with new kit board into the corresponding knock-outs in sheet metal electrical box

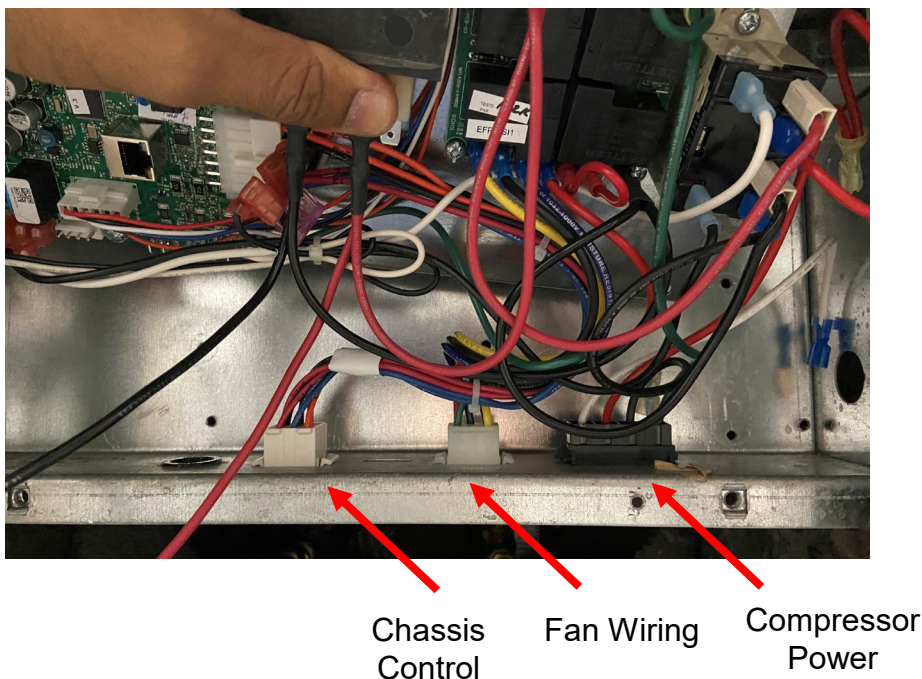

- 2) Position electrical kit plate towards the left to allow enough space for the Capacitor to be mounted on the right-hand side.
- 3) Secure the electrical plate using 4 sheet metal screws. You may need to drill pilot holes.

Capacitor
Location

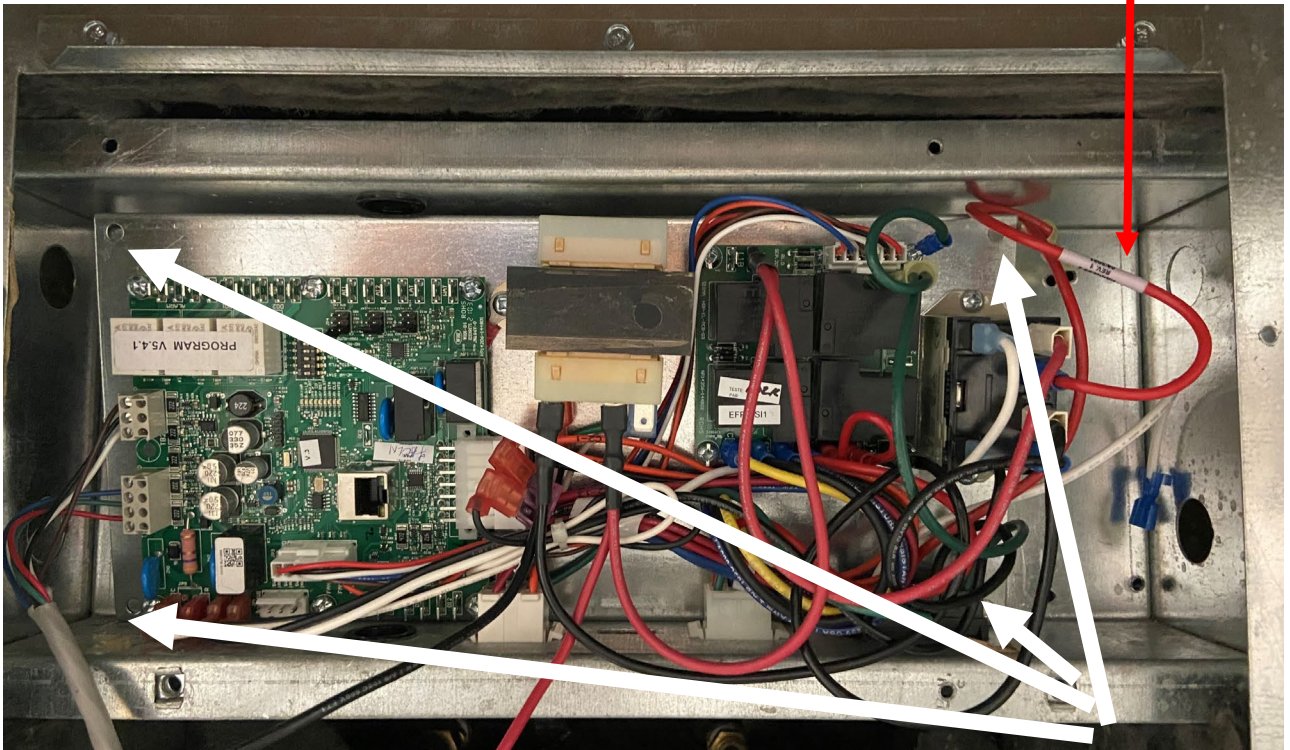

4 x Screws

STEP 4) Install Disconnect and New Cover Plate

- 1) Screw disconnect to the new cover plate provided. **Position disconnect with switch down in the OFF position.**
- 2) Connect the power leads (RED and BLACK) from control kit transformer to the LOAD Side of the disconnect.
- 3) Ensure ground wire is fastened to sheet metal or electrical plate grounding lug.
- 4) Plug the 3-speed fan speed moxex connector to the control board fan moxex connector

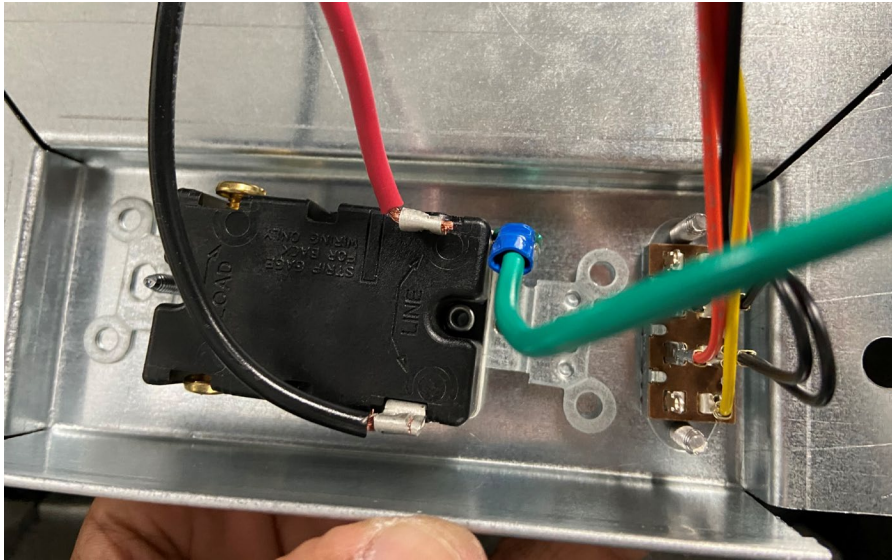

STEP 4) Cont'd

- 4) Place disconnect cover plate into position using existing lower clearance hole.
- 5) Connect existing Capacitor on the right-hand side using the RED power wire from the compressor relay and compressor plug (see electrical schematic for more details). Secure Capacitor to electrical box using a strap.

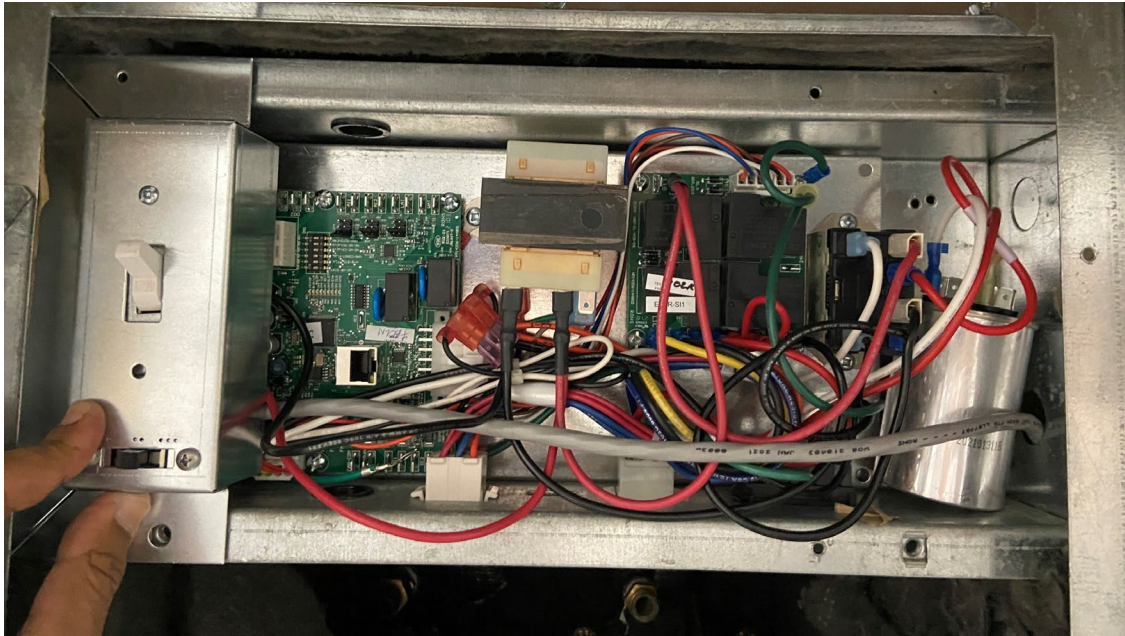

STEP 5) Final Wiring Connections

- 1) Use existing thermostat harness with molex removed (in Step 1) and create bare wire pigtails. Wire nut these to the new thermostat block. See wiring diagram showing connection to the control board thermostat terminal block.

G1 = Low Speed, G2 = Medium Speed, G3 = High Speed

R = Power

Y = Compressor

O/B = Reversing Valve

C = Common (Optional)

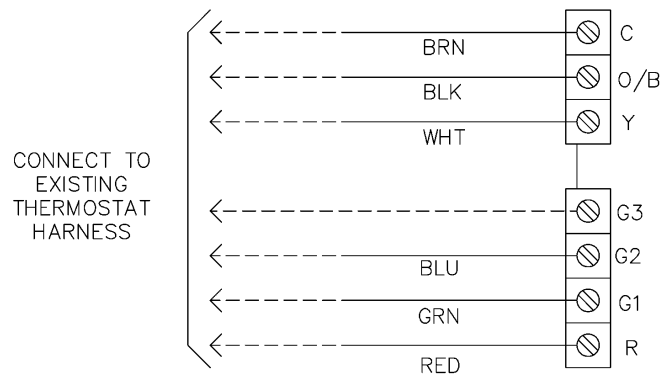

STEP 5) Cont'd

- 2) Fan speeds can be set one of two ways:
1. By thermostat (wired to G1, G2, G3) terminals or
 2. By 3-Speed Fan Switch.

Tip: A bank of 6 DIP switches on the board controls a variety of functions. DIP switch #6 (FAN) sets fan control. Set to ON position for thermostat control (wired), or OFF position for 3-speed fan switch control.

See **Wiring Thermostat & DIP Switches** page for more information.

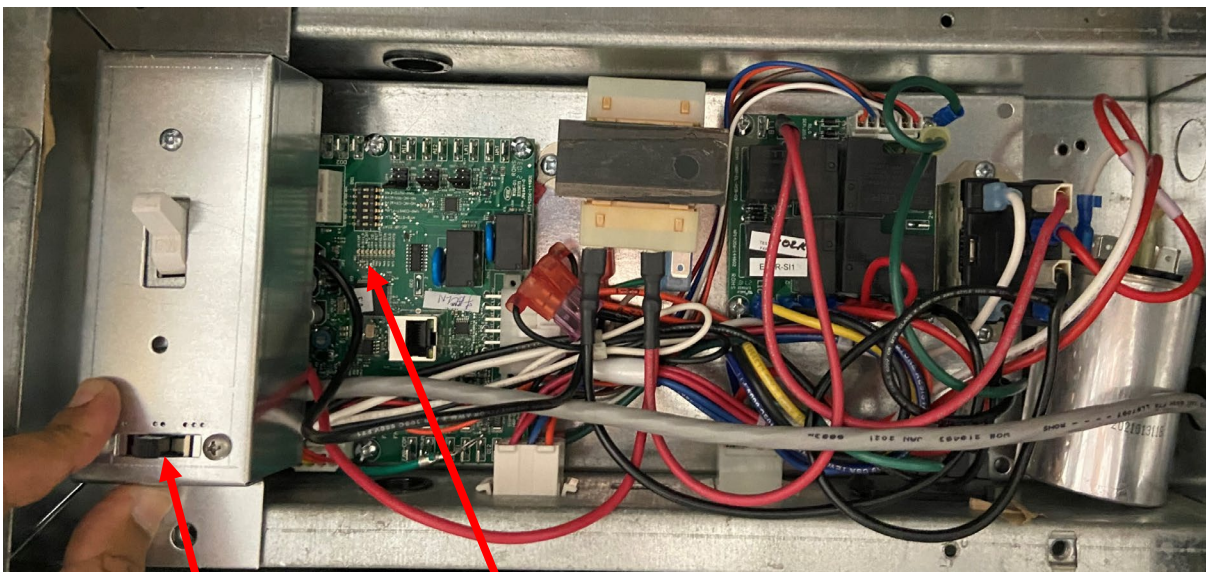

3-Speed Fan Switch
(Low, Med, High)

DIP
Switches

STEP 6) Fan Relay Board Wiring – Optional (See Below)

Majority of units will have PSC fan motors. Some units would have received ECM Fans from factory. The **Fan Relay Board** provided with the new kit can be configured for several fan types: PSC (factory default); EON-42; or X13. This also allows existing units with PSC motors to be field retrofitted to ECM. The standard factory default configuration is for PSC Motor. Factory will wire the **Fan Relay Board** to your specific requirements if requested at time of purchase. If this was not configured, please check the wiring table below. Contact Technical Support for more information if needed.

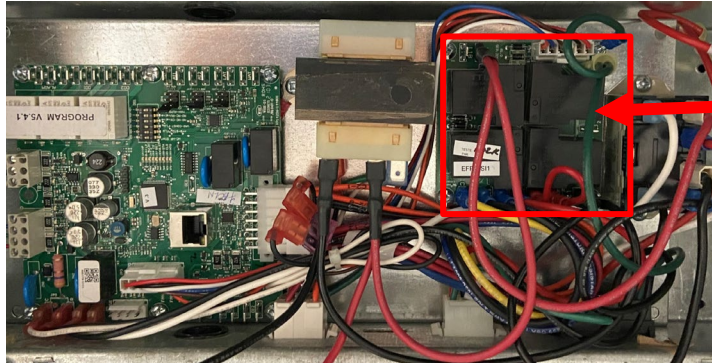

Fan Relay Board

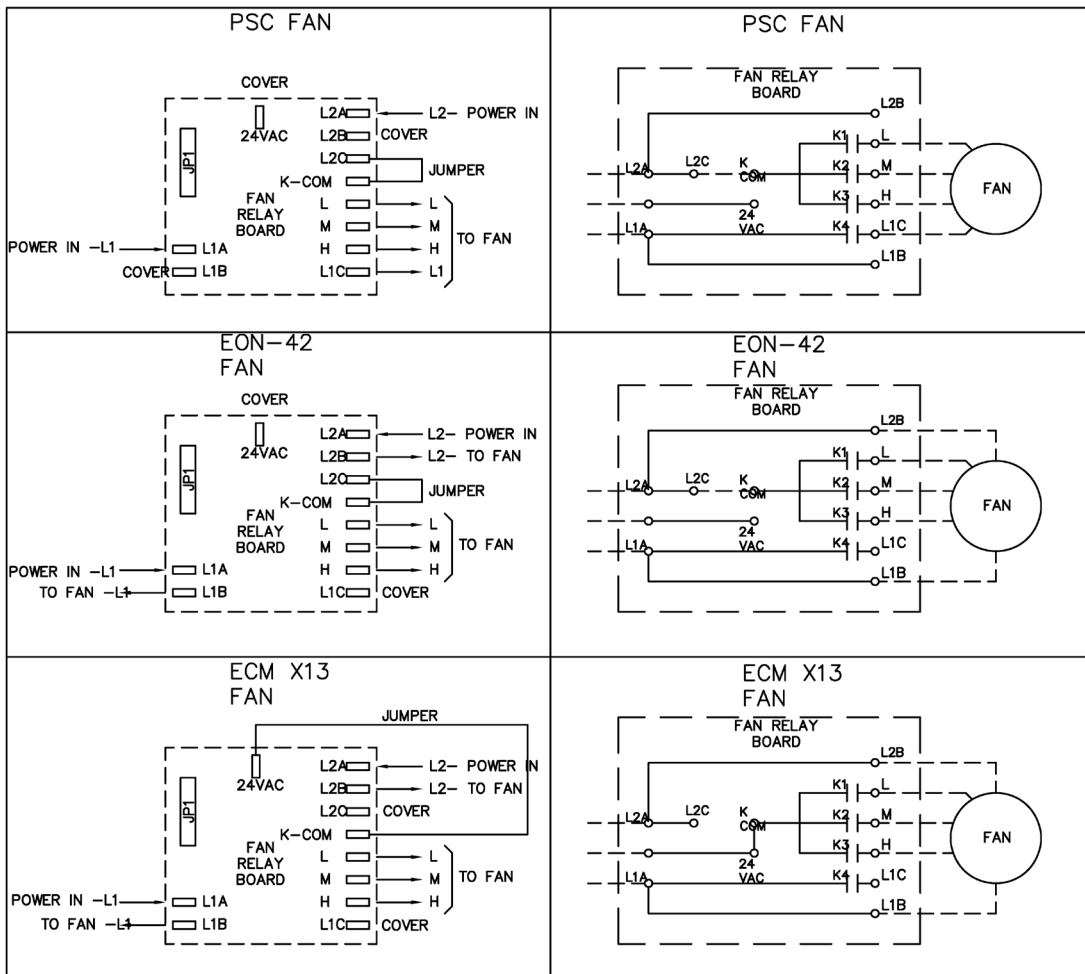

STEP 7) Re-Install Covers

- 1) Place chassis service cover panel into place and fasten.
- 2) Install electrical box cover plate.
- 3) Reconnect power at break and disconnect. Check thermostat and fan speed operation. See **Start-Up** page.

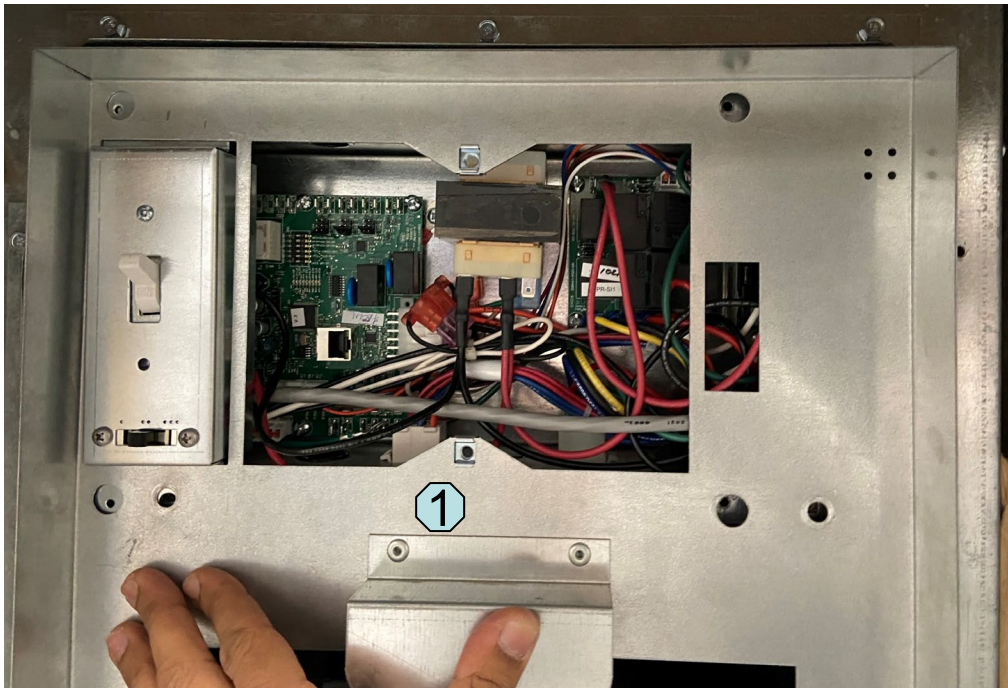

Electrical Schematic – PSC Fan

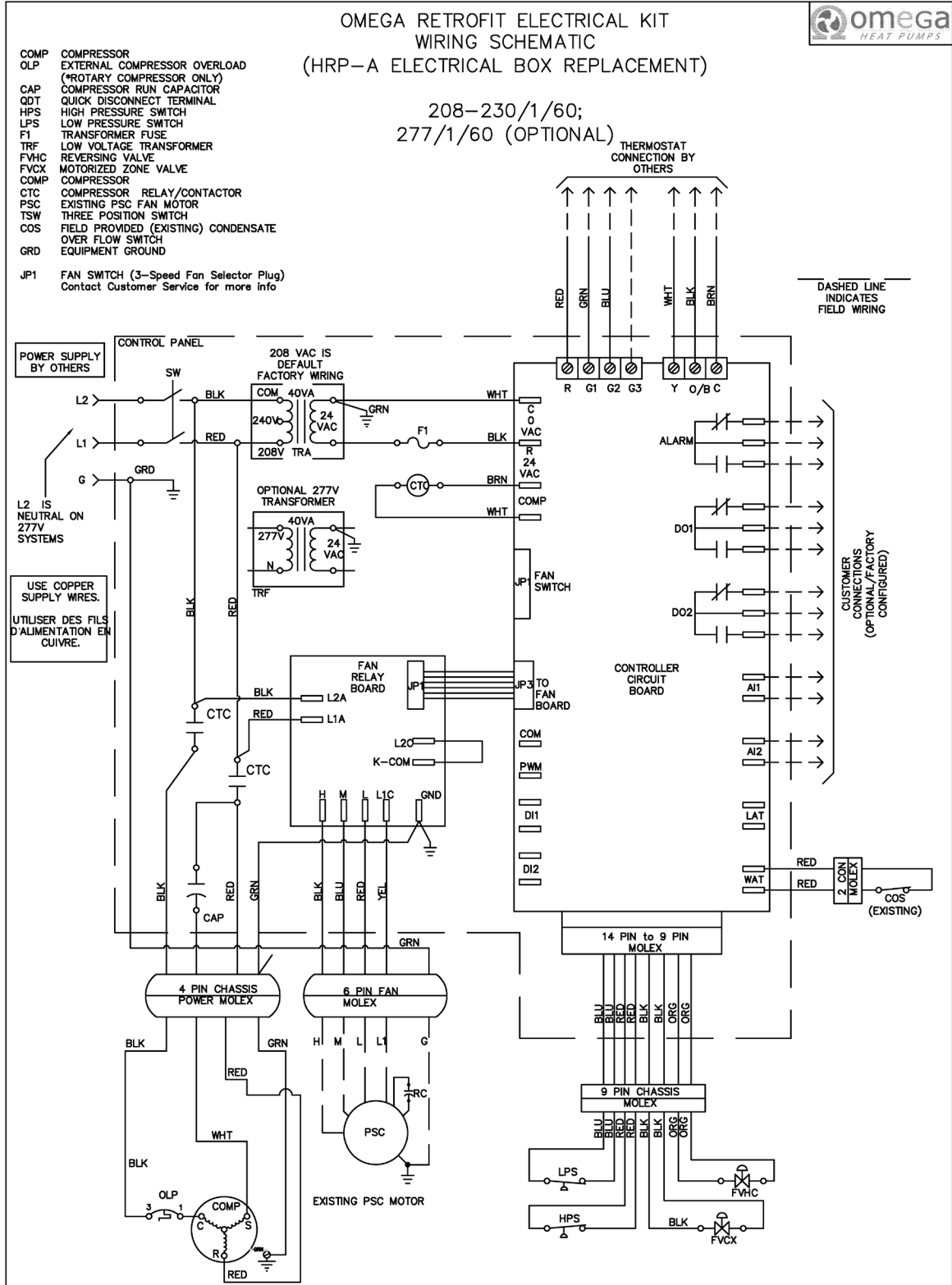

Wiring Thermostat and DIP Switches on Board

HRP Kit

DIP	DESCRIPTION	OFF	ON
1	Tstat Type	Heat/Cool Tstat	HeatPump Tstat
2	HP Type		X
3	FlowType		X
4	Coax Valve		X
5	Reversing Valve (RV)/ HeatCoil		X
6	FanMode		X

Factory Default DIP switch settings

Control board comes with 6 DIP switches that are factory set. If you using Heat/Cool Thermostat set DIP#1 to OFF, if using Heat Pump Thermostat set DIP#1 to ON. Default from factory is Heat Pump with Reversing Valves Energized to Cool.

Wiring of Thermostat harness to either Heat/Cool or Heat Pump thermostats:

Wiring - Thermostat Type

TERMINAL BLOCK	WIRE	DIP 1 (ON) = HeatPump Thermostat	DIP 1 (OFF) = HEAT/COOL Thermostat	COLOR
TB1 #4	R	24VAC – Line (R)	24VAC – Line (R)	RED
TB1 #3	G1	Low Speed	Low Speed	GREEN
TB1 #2	G2	Medium Speed	Medium Speed	BLUE
TB1 #1	G3	High Speed	High Speed	-
TB2 #3	Y	Call for Compressor	Call for Cooling	WHITE
TB2 #2	O/B	Call for Reversing Valve	"W" Call for Heating	BLACK
TB2 #1	C	Common (Optional)	Common (Optional)	BROWN

Start-up

- A) Close disconnect switch
- B) Set thermostat to a setpoint above room temperature, set system to COOL with fan on AUTO. The compressor should not run.
- C) Lower the thermostat temperature setting until the fan and compressor energize.
- D) Check blower is running smoothly during compressor operation.
- E) Check compressor and blower amps are within nameplate data.
- F) Set thermostat to the OFF position. Unit compressor and fan should stop running.
- G) Set thermostat to the HEAT position and setpoint below room temperature.
- H) Adjust thermostat temperature higher until the fan and compressor energize.
- I) Check blower is running smoothly during compressor operation.
- J) Check compressor and blower amps are within nameplate data.
- K) Set the thermostat to the desired temperature.

Controller

TEST MODE

A Test mode feature will reduce all unit timer delays on this control board to <30 seconds.

To enable test mode jumper “D11” pins on the microprocessor board. Remove jumper once test mode is complete.

SEQUENCE OF OPERATION

Call for Heating and Cooling

Demand call for Heating or Cooling are initiated at the thermostat.

Call for Compressor

When a compressor request is made, the optional Motorized Auto Shut-Off Control Valve (COAX Flow valve) will open.

The compressor contactor will then be energized so long as none of the following fault conditions are present:

- High-Pressure Alarm
- Low-Pressure Alarm
- Condensate Overflow Alarm* (Optional)
- Compressor Anti-Short Cycle 7 min. timer has not expired

*Optional field supplied and wired. The terminals come with a jumper when not used.

Call for Compressor Terminated

When call for compressor request is terminated, the optional Motorized Auto Shut-Off Control Valve (COAX Flow Valve) and the blower fan will remain open for an additional 3 minutes.

Low-Pressure Bypass

During a call for compressor, the low-pressure switch is bypassed for the first 2 minutes of compressor operation to prevent nuisance low-pressure start-ups.

Timers and Interlocks

Microprocessor board utilizes a number of timers and interlocks in the control sequence of the unit.

Anti-Short Cycle Timer

The compressor anti-short cycle timer of 7 minutes starts every time a call for compressor is terminated to prevent compressor over cycling.

Fan-On Timer

The Fan-On timer of 3 minutes starts anytime there is a call for fan request.

Fan-Off Timer

The Fan-Off timer of 3 minutes starts anytime a call for compressor is terminated to ensure fan runs for a period of 3 minutes after the compressor turns off.

Valve Open Timer**

The valve open timer of 1 minutes starts anytime a fan and compressor request are made to develop flow in the water coil.

Valve Closed Timer**

The valve closed timer of 1 minutes starts anytime a call for compressor is terminated to allow for flushing of the water coil.

Random Wait Time on Unit Power Up

Microprocessor controller uses a random wait time during unit start up between 1-30 seconds.

**Only with optional motorized Auto Shut-Off Control valve.

Control Board LED Code Table

LED	Description	LED Code	Alarm Description
HP	High Pressure	Red = Solid	High pressure alarm. Hard Lock-Out. 3 Trips
		Red = Blinking	High pressure alarm. Soft Lock-Out
LP	Low Pressure	Red = Solid	Low pressure alarm. Hard Lock-Out. 3 Trips
		Red = Blinking	Low pressure alarm. Soft Lock-Out
WLDT**	Water Loop Discharge Temp	Red = Solid	Water loop discharge temperature too hot. Non-latching alarm
		Red = Blinking	Sensor open/missing or close/shorted. Non-latching alarm, replace sensor
CO*	Condensate Overflow	Red = Solid	Condensate overflow alarm. Hard Lock-Out. 2 Trips
		Red = Blinking	Condensate overflow alarm. Soft Lock-Out
RST**	Refrigerant Suction Temp	Red = Blinking	Sensor open/missing or close/shorted. Non-latching alarm. Replace sensor
WLST**	Water Loop Supply Temp	Red = Solid	Water loop supply temperature too hot. Non-Latching fault
		Red = Blinking	Sensor open/missing or close/shorted. Non-latching alarm, replace sensor
STA	PCB Status	Green = Blinking	PCB is operational
CLG	Cooling	Green = Solid	Cooling call from thermostat input
HTG	Heating	Green = Solid	Heating call from thermostat input

* Optional, ** Not Used

LP Alarm LED	HP Alarm LED	COS Alarm LED
LP SoftLock = 0, Off	HP SoftLock = 0, Off	COS SoftLock = 0, Off
LP SoftLock = 1, Blink 1 every 1 Sec	HP SoftLock = 1, Blink 1 every 1 Sec	COS SoftLock = 1, Blink 2 every 1 Sec
LP SoftLock = 2, Blink 2 every 1 Sec	HP SoftLock = 2, Blink 2 every 1 Sec	COS SoftLock = 2, Solid = HARD LOCK
LP SoftLock = 3, Solid = HARD LOCK	HP SoftLock = 3, Solid = HARD LOCK	